

DUE TO THE NATURE OF THE MATERIALS, OVERALL DIMENSIONS ARE APPROXIMATE

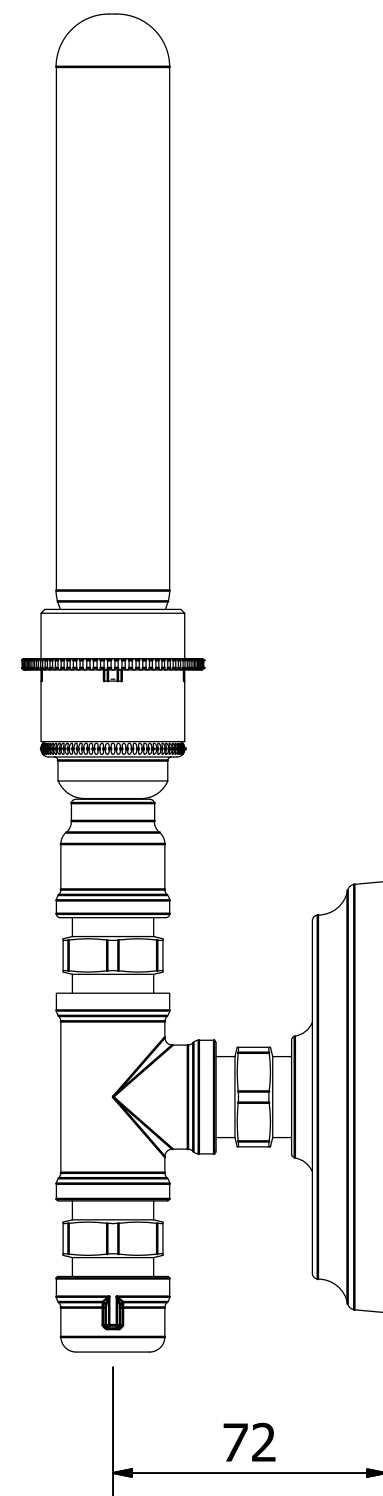

CEILING PLATE MOUNTING DETAIL

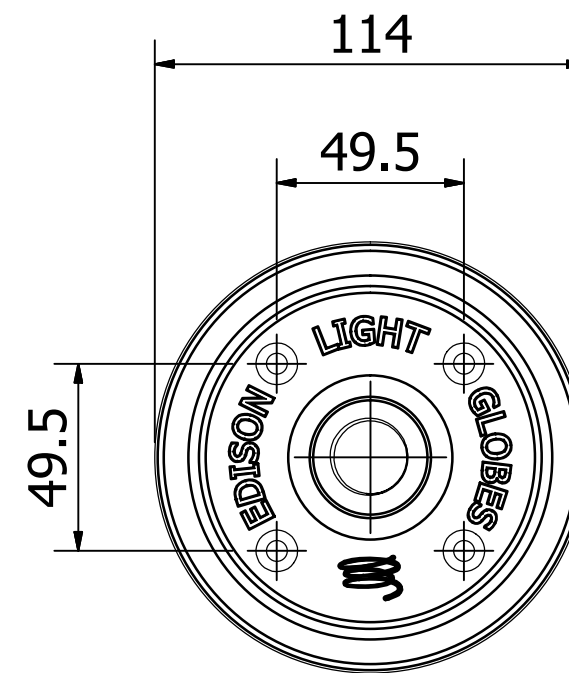

Edison Light Globes globes, flex and fittings



REVISION HISTORY				
REV	DESCRIPTION	DATE	APPROVED	CR
A0	Initial Release		PG	

USE ONLY FOR JOB NO.	Material	Finish		
	SCALE: DNS	© Edison Light Globes Pty Ltd edisonlightglobes.com		
UNCONTROLLED DOCUMENT	Designed by	Checked by	Approved by	Date
	DavidG	PG	PG	25/01/2014
Dimensions in millimetres Limit on untoleranced unmachined dimensions ± 0.2mm No decimal place 1mm 1 decimal place ± 0.3mm 2 decimal places ± 0.1mm General unmachined angular tolerance ±1° Tolerance to be non-cumulative		Plumbing Pipe Wall Lamp E27 Single		
			Revision	Sheet
				1 / 2

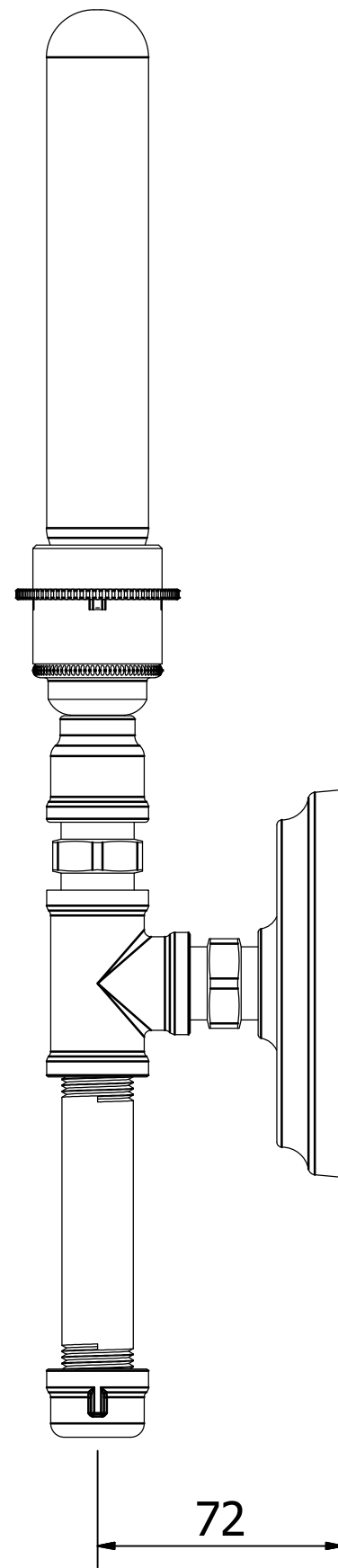
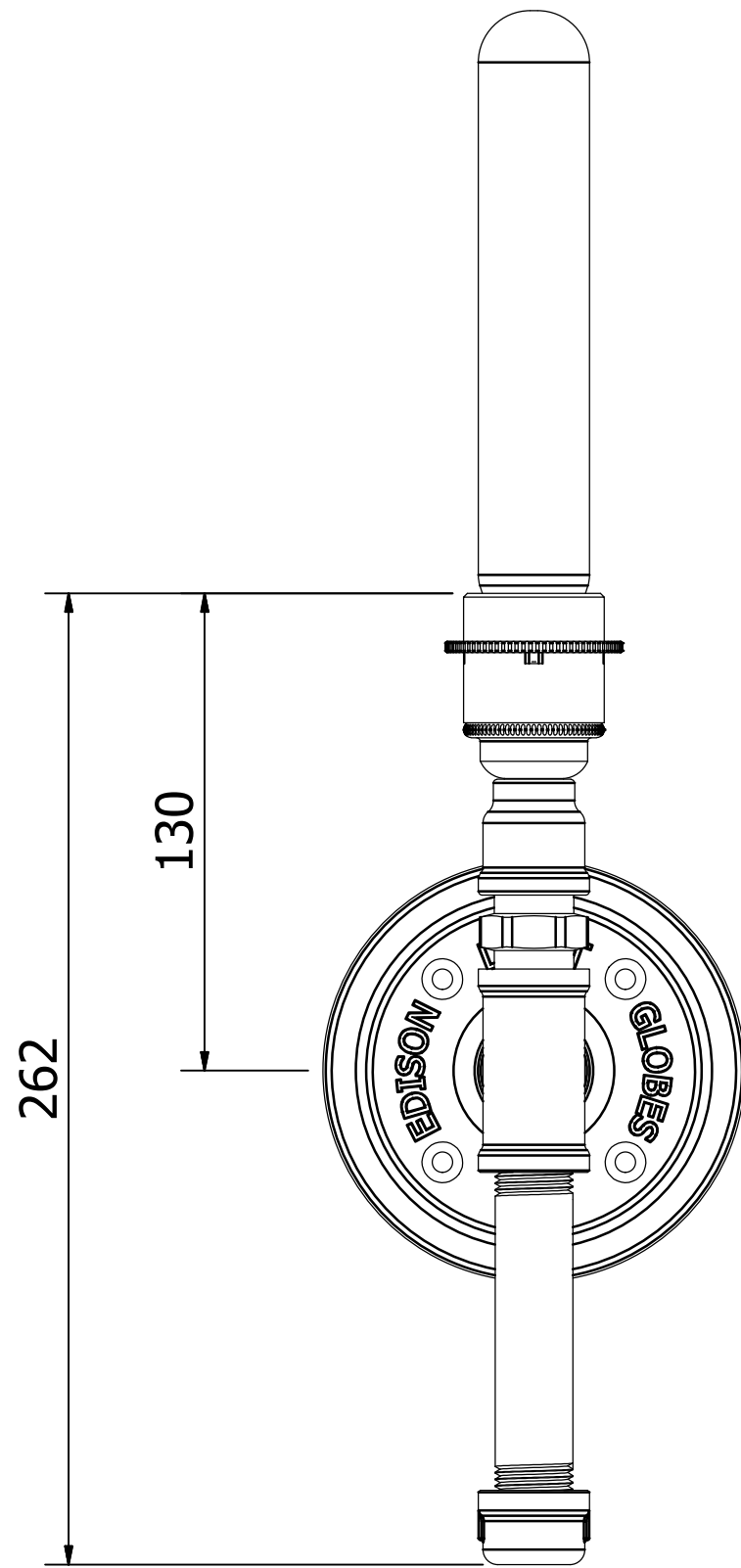

CEILING PLATE MOUNTING DETAIL

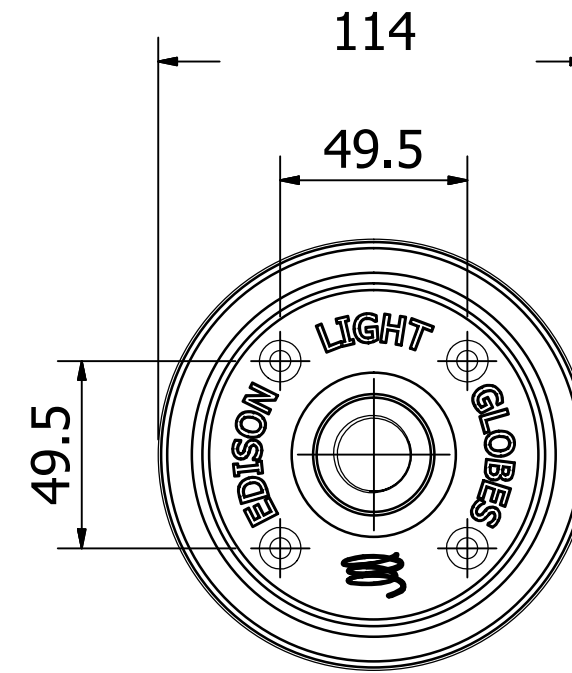

Edison Light Globes globes, flex and fittings

USE ONLY FOR JOB NO.	Material	Finish				
	SCALE: DNS				© Edison Light Globes Pty Ltd edisonlightglobes.com	
UNCONTROLLED DOCUMENT	Designed by	Checked by	Approved by	Date	Project	Date
	DavidG		PG			25/01/2014
	Dimensions in millimetres Limit on untoleranced unmachined dimensions ± 0.2mm No decimal place 1mm 1 decimal place ± 0.3mm 2 decimal places ± 0.1mm General unmachined angular tolerance ±1° Tolerance to be non-cumulative			Plumbing Pipe Wall Lamp E27 Single		
				Revision	Sheet 2 / 2	